



QUICK SELECTION / Selezione veloce input speed (n_1) = 1400 min⁻¹

Output Speed n_2 [min ⁻¹]	Ratio i	Motor power P_{1M} [kW]	Output torque M_{2M} [Nm]	Service factor f.s.	Nominal power P_{1R} [kW]	Nominal torque M_{2R} [Nm]	Available B5 motor flanges			Available B14 motor flanges			Output Shaft 	Ratios code	
							-D	-E	-F	-R	-T	-U			
							80	90	100 112	80	90	100 112			
481	2.91	4	76	1.8	7.2	140	B	B		B	B		3499	standard	01
373	3.75	4	98	1.6	6.4	160	B	B		B	B		28105	ø30	02
263	5.33	4	140	1.2	4.8	170	B	B		B	B		21112		03
219	6.39	4	167	1.0	4.0	170	B	B		B	B		18115	ø25	04
178	7.85	4	205	1.1	4.3	225	B	B		B	B		13102	ø35	05

On request

The dynamic efficiency is **0.98** for all ratios

Motor Flanges Available Flange Motore Disponibili
 B) Supplied with Reduction Bushing Fornito con Bussola di Riduzione
 B) Available on Request without reduction bushing Disponibile a Richiesta senza Bussola di Riduzione
 C) Motor Flange Holes Position Posizione Fori Flangia Motore

EN Unit **FA41** is supplied with synthetic oil for lifetime lubrication, no maintenance is necessary. See table 1 for lubrication and recommended quantity. In table 2 please see possible radial loads and axial loads on the gearbox.

I Il riduttore **FA41** viene fornito completo di olio sintetico per la lubrificazione permanente e non necessita di alcuna manutenzione. Vedi tab.1 per oli e quantità consigliati. In tab.2 sono presenti i carichi radiali e assiali applicabili al riduttore.

D Das Getriebe **FA41** ist mit synthetischem Öl gefüllt und ist lebensdauergeschmiert. In Tabelle 1 ist die Schmiermenge und das empfohlene Schmiermittel angegeben. In Tabelle 2 sind die zulässigen Radial- und Axialbelastungen des Getriebes aufgeführt.

F Le réducteur **FA41** est fourni complet avec de l'huile synthétique pour la lubrification permanente et ne nécessite aucun entretien. Voir tableau 1 concernant les huiles et les quantités conseillées. Les charges radiales et axiales applicables au réducteur sont précisées dans le tableau 2.

E El reductor tamaño **FA41** se suministra, lubricado de por vida con aceite sintético y no requieren mantenimiento alguna. Ver tabla 1, para cantidades y aceites recomendados. En la tabla 2, se encuentran las cargas radiales y axiales admitidas por el reductor.

Standard supplied	For these mounting position specify in the order or add oil Per queste posizioni specificare in fase d'ordine o aggiungere olio				
1.10 LT	0.65 LT	0.65 LT	0.65 LT	1.15 LT	0.80 LT
SHELL Omala S4 WE 320			ENI Telium VSF 320		

For all details on lubrication and plugs check our website tab. 1
Per maggiori dettagli su lubrificazione e tappi olio vedi il nostro sito web

RADIAL AND AXIAL LOADS

Output shaft
Albero di uscita

F_R (N)
 F_A (N)

$F_{eq} = F_R \cdot \frac{127.5}{X+97.5}$

n_2 [min ⁻¹]	FA	FR	n_2 [min ⁻¹]	FA	FR	n_2 [min ⁻¹]	FA	FR
300	300	1500	140	390	1950	70	490	2450
250	320	1600	120	410	2050	40	590	2950
200	350	1750	85	460	2300	15	800	4000

On request reinforced bearings to increase loads.
A richiesta cuscinetti rinforzati per aumentare i carichi.

tab. 2

PFA41C...

Basic gearbox
Riduttore base

Gearbox weight
peso riduttore **12.1 kg**

M. flanges	Kit code	øF	A
80/90B5	K023.4.042	200	179.5
100/112B5	K023.4.043	250	188.5
80B14	K085.4.046	120	179.5
90B14	K085.4.045	140	179.5
100/112B14	K085.4.047	160	188.5

● Available torque arms,
see our web site
Bracci di reazione disponibili,
consulta il nostro sito web

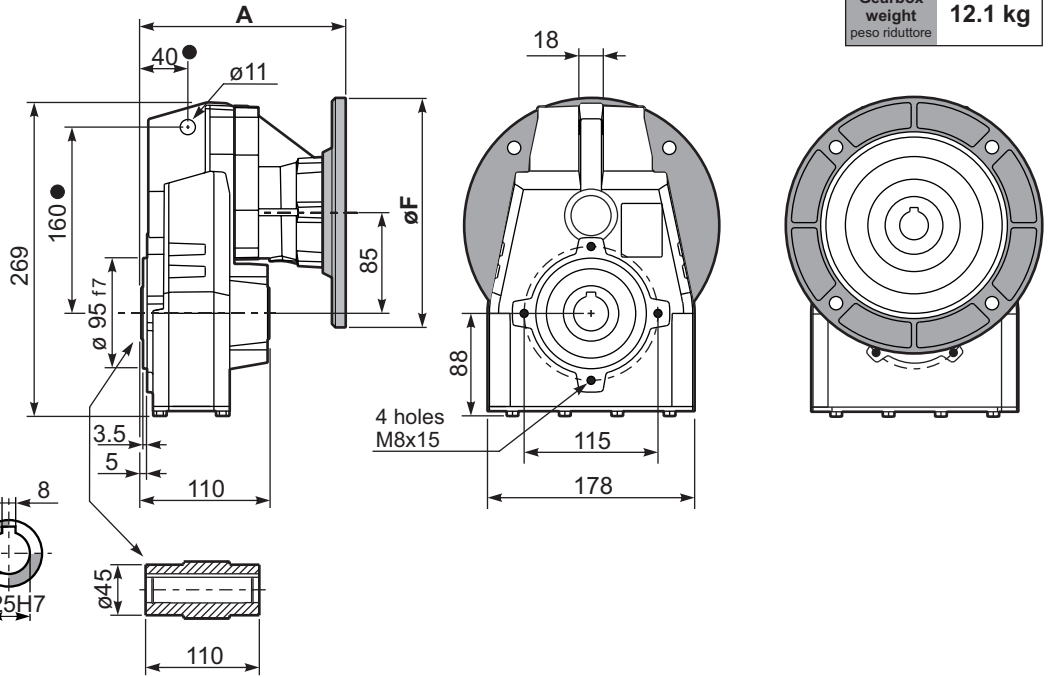

Standard
Hollow shaft

On request
A richiesta

PFA41...-F...

Output flange
Flangia uscita

M. flanges	k1
80/90B5	215.5
100/112B5	221.5
80B14	213.5
90B14	213.5
100/112B14	224.5

Available output flanges
Flange di uscita

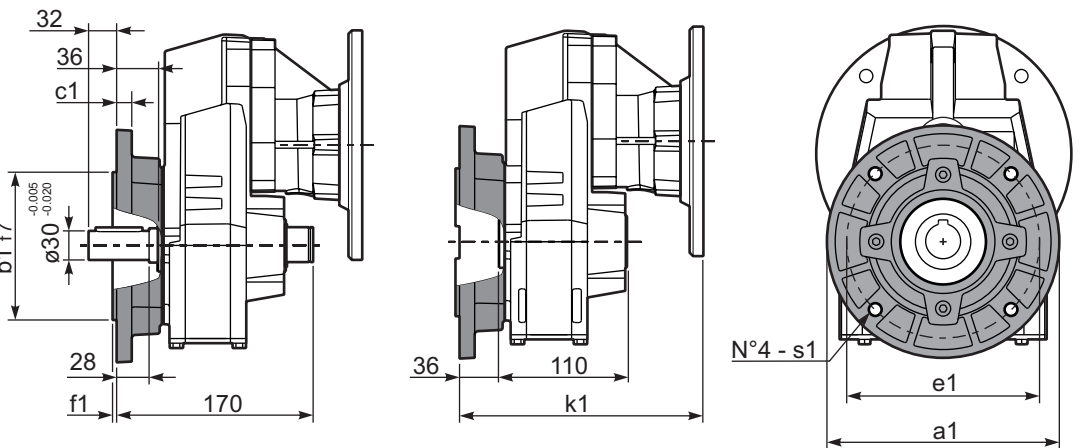

a1 ø	b1	c1	e1	f1	s1	Kit code
160	110	10	130	3	9	KX5A.9.010
200	130	13	165	3.5	11	KX5A.9.011
250	180	14	215	4	14	KX5A.9.012

PFA41 A...

Single output shaft
Albero uscita semplice

