



QUICK SELECTION / Selezione veloce

input speed (n_1) = 1400 min⁻¹

Output Speed n_2 [min ⁻¹]	Ratio i	Motor power P_{1M} [kW]	Output torque M_{2M} [Nm]	Service factor $f.s.$	Nominal power P_{1R} [kW]	Nominal torque M_{2R} [Nm]	Available B5 motor flanges					Available B14 motor flanges				Output Shaft 	Ratios code	
							-C	-D	-E	-F	-G	-R	-T	-U	-V			
							71	80	90	100 112	132	80	90	100 112	132			
213	6.57	7.5	312	1.2	8.8	380	B										3018	01
185	7.56	7.5	358	1.1	7.9	390	B										3016	02
159	8.82	7.5	419	1.0	7.1	410	B										3014	03
113	12.39	7.5	588	1.0	7.2	580	B										2018	04
98	14.24	5.5	499	1.2	6.4	600	B										2016	05
84	16.75	5.5	587	1.1	6.1	665	B										1618	06
73	19.25	5.5	675	1.0	5.4	675	B										1616	07
64	21.78	4	558	1.2	4.7	675	B										1318	08
56	25.04	4	642	1.1	4.1	675	B										1316	09
47.9	29.23	4	750	0.9	3.5	675	B										1314	10
45.7	30.65	3	592	1.1	3.4	675	B										1116	11
39.1	35.78	3	691	1.0	2.9	675	B										1114	12
36.3	38.55	2.2	548	1.1	2.3	580	B										818	13
31.6	44.32	2.2	630	1.1	2.3	665	B										816	14
27.1	51.74	2.2	735	0.9	2.0	675	B										814	15
22.9	61.03	1.1	437	1.1	1.2	480	B										616	16
19.6	71.25	1.1	510	1.1	1.2	560	B										614	17

The dynamic efficiency is **0.96** for all ratios

- Motor Flanges Available**
Flange Motore Disponibili
- B) Supplied with Reduction Bushing**
Fornito con Bussola di Riduzione
- B) Available on Request without reduction bushing**
Disponibile a Richiesta senza Bussola di Riduzione
- C) Motor Flange Holes Position**
Posizione Fori Flangia Motore

EN Unit **702C** is supplied with synthetic oil for lifetime lubrication, no maintenance is necessary. See table 1 for lubrication and recommended quantity. In table 2 please see possible radial loads and axial loads on the gearbox.

I Il riduttore **702C** viene fornito completo di olio sintetico per la lubrificazione permanente e non necessita di alcuna manutenzione. Vedi tab.1 per oli e quantità consigliati. In tab.2 sono presenti i carichi radiali e assiali applicabili al riduttore.

D Das Getriebe **702C** ist mit synthetischem Öl gefüllt und ist lebensdauergeschmiert. In Tabelle 1 ist die Schmiermenge und das empfohlene Schmiermittel angegeben. In Tabelle 2 sind die zulässigen Radial- und Axialbelastungen des Getriebes aufgeführt.

F Le réducteur **702C** est fourni complet avec de l'huile synthétique pour la lubrification permanente et ne nécessite aucun entretien. Voir tableau 1 concernant les huiles et les quantités conseillées. Les charges radiales et axiales applicables au réducteur sont précisées dans le tableau 2.

E El reductor tamaño **702C** se suministra, lubricado de por vida con aceite sintético y no requieren mantenimiento alguna. Ver tabla 1, para cantidades y aceites recomendados. En la tabla 2, se encuentran las cargas radiales y axiales admitidas por el reductor.

Standard supplied	For these mounting position specify in the order or add oil Per queste posizioni specificare in fase d'ordine o aggiungere olio					
2.10 LT	1.40 LT	1.40 LT	1.30 LT	2.25 LT	1.60 LT	Ask
AGIP Telium VSF 320			SHELL Omala S4 WE 320			

For all details on lubrication and plugs check our website **tab. 1**
Per maggiori dettagli su lubrificazione e tappi olio vedi il nostro sito web

RADIAL AND AXIAL LOADS

Output shaft
Albero di uscita

F_R (N)
 F_A (N)

$F_{eq} = F_R \cdot \frac{70}{X+35}$
 F_{eq} (N)

n_2	FA	FR	n_2	FA	FR	n_2	FA	FR
300	680	3400	140	960	4800	70	1300	6500
250	760	3800	120	1040	5200	40	1460	7300
200	900	4500	85	1120	5600	15	1800	9000

On request reinforced bearings to increase loads.
A richiesta cuscinetti rinforzati per aumentare i carichi.

Input shaft
Albero in entrata

n_1	FA	FR
1400	400	2000
900	440	2200
500	440	2200

tab. 2

P702C**S6**... With feet
Con piedini

Gearbox weight **30.0 kg**
peso riduttore With flange
With feet **33.5 kg**

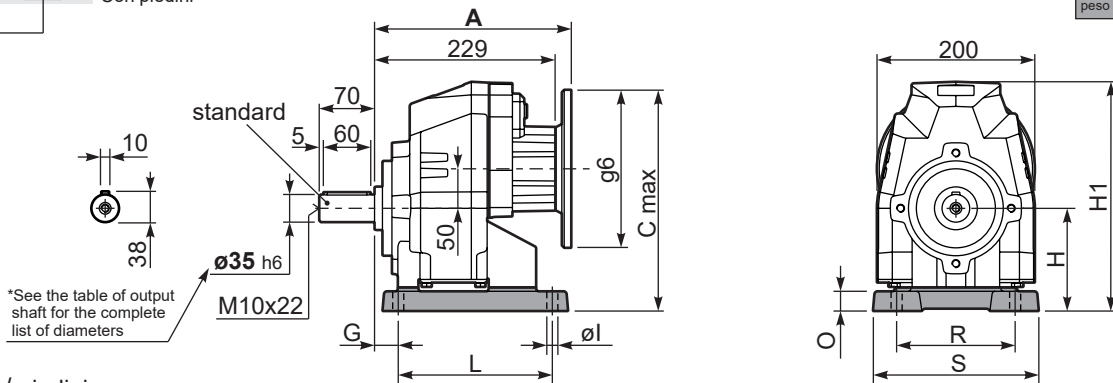

Feet / piedini

Feet Code	Market reference	G	H	R	L	S	H1	O	øl	B5 max. Flange	kit code
B4	412/3	19.5	130	180	149.5	216	290	25	14	-	KC70.9.022
S6	67	30	130	150	195	210	290	25	14	-	KC70.9.024
H5	025/253	35	160	170	175	220	320	30	16	-	KC70.9.023
-	-	-	-	-	-	-	-	-	-	-	-
-	-	-	-	-	-	-	-	-	-	-	-

P702C-**F**... Output flanges
flange di uscita

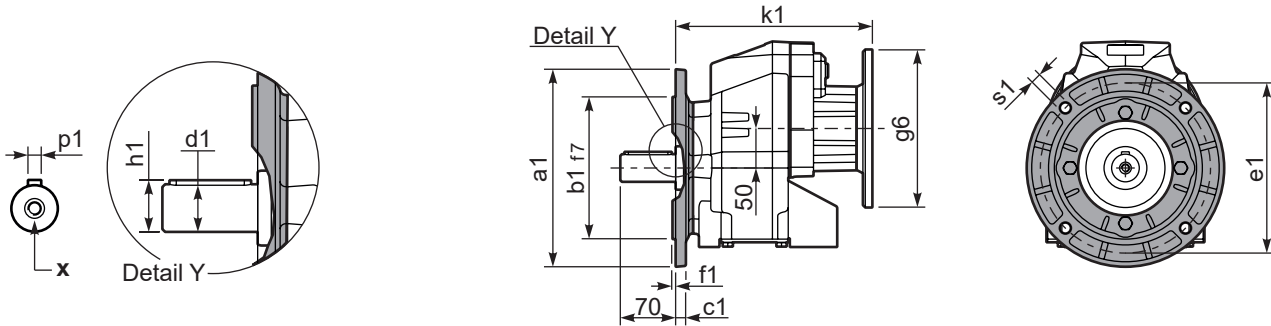

*Available output shaft / Albero di uscita

	Shaft - d1	p1	h1	x
Standard	ø 35x70	10	38	M10x22
On request A richiesta	ø 40x80	12	43	M12x28

Available output flanges / flange di uscita

a1 ø	b1	c1	e1	f1	s1	kit code
200	130	11	165	3.5	11	KC70.9.012
250	180	13	215	4	14	KC70.9.013
-	-	-	-	-	-	-

With flange and feet only on request. Ask for compatibility

P702C-**N**... Basic gearbox
Riduttore base

R702C-**N**... Input Shaft
Albero in entrata

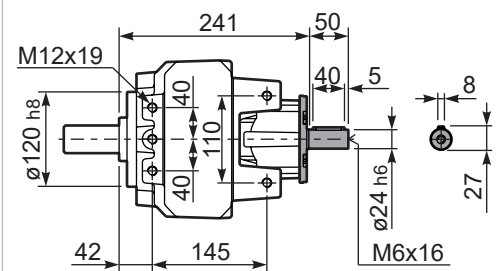
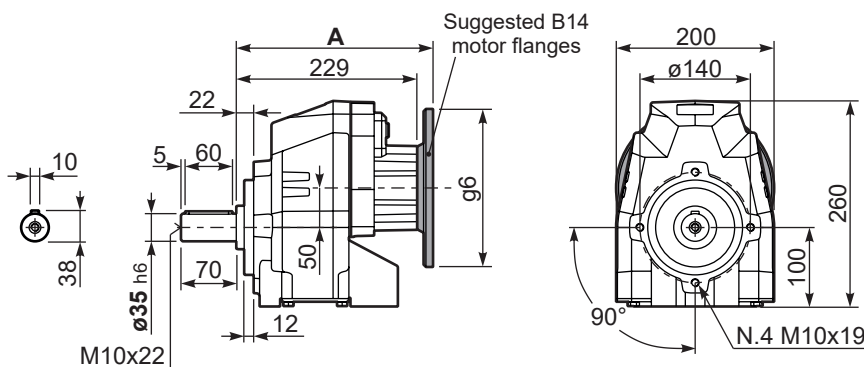

B5 Motor Flanges	A	C _{max}	g6	k1	kit code
71 B5	247.5	290	160	247.5	K023.4.041
80/90 B5	249.5	310	200	249.5	K023.4.042
100/112 B5	258.5	335	250	258.5	K023.4.043
132 B5	276.5	360	300	276.5	KC50.4.043

B14 Motor Flanges	A	C _{max}	g6	k1	kit code
80 B14	249.5	270	120	249.5	K085.4.046
90 B14	249.5	280	140	249.5	K085.4.045
100/112 B14	258.5	290	160	258.5	K085.4.047
132 B14	276.5	310	200	276.5	KC50.4.041