

#### QUICK SELECTION / Selezione veloce

input speed ( $n_1$ ) = 1400 min<sup>-1</sup>

Output Speed $n_2$ [min <sup>-1</sup> ]	Ratio $i$	Motor power $P_{1M}$ [kW]	Output torque $M_{2M}$ [Nm]	Service factor f.s.	Nominal power $P_{1R}$ [kW]	Nominal torque $M_{2R}$ [Nm]	Available B5 motor flanges				Available B14 motor flanges			Dynamic efficiency <b>RD</b>	Tooth Module  [mm]	Ratios code 
							-B	-C	-D	-E	-Q	-R	-T			
							63	71	80	90	71	80	90			
16.8	<b>83.2</b>	1.5	587	1.1	<b>1.7</b>	<b>660</b>					C			69	3.5	01
13.9	<b>100.5</b>	1.5	699	0.8	<b>1.3</b>	<b>594</b>					C			68	2.9	02
10.6	<b>132</b>	1.1	634	0.9	<b>0.95</b>	<b>550</b>					C			64	2.2	03
8.0	<b>176</b>	0.75	666	1.2	<b>0.90</b>	<b>803</b>	B				C			74	4.7	04
6.7	<b>208</b>	0.75	766	0.9	<b>0.65</b>	<b>660</b>	B				C			72	4.0	05
5.7	<b>245</b>	0.55	634	1.0	<b>0.57</b>	<b>660</b>	B				C			69	3.5	06
4.7	<b>296</b>	0.55	755	0.8	<b>0.43</b>	<b>594</b>	B				C			68	2.9	07
4.2	<b>334</b>	0.55	865	0.8	<b>0.42</b>	<b>660</b>	B				C			69	3.5	08
3.5	<b>403</b>	0.37	692	0.9	<b>0.32</b>	<b>594</b>	B				C			68	2.9	09
2.6	<b>529</b>	0.25	577	1.0	<b>0.24</b>	<b>550</b>	B				C			64	2.2	10
2.2	<b>624</b>	0.25	628	0.8	<b>0.21</b>	<b>528</b>	B				C			59	1.9	11

**Motor Flanges Available**  
Flange Motore Disponibili

**B) Supplied with Reduction Bushing**  
Fornito con Bussola di Riduzione

**B) Available on Request without reduction bushing**  
Disponibile a Richiesta senza Bussola di Riduzione

**C) Motor Flange Holes Position**  
Posizione Fori Flangia Motore

**EN** Unit **P10** is supplied without lubricant and equipped with a breather, level and drain plugs. User can add mineral oil keeping existing plugs. Should the user wish to fill it with synthetic oil, it is recommended to replace the existing plugs with a closed plug. Primary reduction unit is supplied with closed plugs and lubricated for life with synthetic oil. See table 1 for lubrication and recommended quantity. In table 2 please see possible radial loads and axial loads on the gearbox.

**I** Il riduttore tipo **P10** è fornito privo di lubrificazione con tappi di sfiato, livello e scarico olio. L'utente può immettere olio minerale mantenendo i tappi esistenti. Se immetterà olio sintetico, dovrà sostituire i tappi esistenti con altri tipo chiuso. La precoppia è fornita con tappi chiusi e lubrificata a vita con olio sintetico. Tab.1 per oli e quantità consigliati. Tab.2 carichi radiali e assiali applicabili al riduttore.

**D** Das Getriebe der Baugröße **P10** wird ohne Schmiermittel geliefert. Es ist jedoch mit Einfüllschraube, Überdruckventil und Ablassschraube ausgerüstet. Das benötigte mineralische Öl kann über die Einfüllschraube eingefüllt werden. Sollte synthetisches Öl bevorzugt werden, so ist sind das eingebaute Überdruckventil durch eine geschlossenen Schraube zu ersetzen. Die Stirnradvorstufe ist Lebensdauer geschmiert und wird mit synthetischem Öl geliefert. Die Stirnradvorstufe ist komplett geschlossen ohne Füllschrauben. In Tabelle 1 ist die Schmiermenge und das empfohlene Schmiermittel angegeben. In Tabelle 2 sind die zulässigen Radial- und Axialbelastungen des Getriebes aufgeführt.

**F** Le réducteur de type **P10** est fourni sans lubrification et avec un bouchon de remplissage, de niveau et d'évacuation de l'huile. L'utilisateur peut y verser de l'huile minérale en conservant les bouchons existants. S'il y versera de l'huile synthétique, il devra substituer les bouchons existants avec d'autres bouchons de type fermé. Le pré couple est fourni lubrifié à vie avec de l'huile synthétique et avec des bouchons fermés. Voir tableau 1 concernant les huiles et les quantités conseillées. Voir tableau 2 concernant les charges radiales et axiales applicables au réducteur

**E** El reductor tamaño **P10** se suministra sin lubricante, provisto de tapones de respiración, nivel y descarga de aceite. El usuario puede utilizar aceite mineral, manteniendo los tapones existentes. Si prefiere utilizar aceite sintético deberá sustituir los tapones existentes por tapones ciegos. La prerreducción se suministra con tapones ciegos, lubricado de por vida con aceite sintético. Ver tabla 1, para cantidades y aceites recomendados. En la tabla 2, se encuentran las cargas radiales y axiales admitidas por el reductor.

<b>B3</b>	<b>B6</b>	<b>B7</b>	<b>B8</b>	<b>V5</b>	<b>V6</b>
1.9/0.14LT	1.35/0.14 LT	1.35/0.14 LT	2.0/0.14 LT	2.0/0.14 LT	2.0/0.14 LT

AGIP Blasias 460

For all details on lubrication and plugs check our website **tab. 1**  
Per maggiori dettagli su lubrificazione e tappi olio vedi il nostro sito web

#### RADIAL AND AXIAL LOADS

**Output shaft**  
Albero di uscita

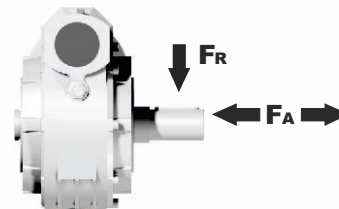

$n_2$ [min <sup>-1</sup> ]	FA [N]	FR [N]
75	800	4000
50	920	4600
25	1200	6000
15-6	1400	7000

**Input shaft**  
albero in entrata

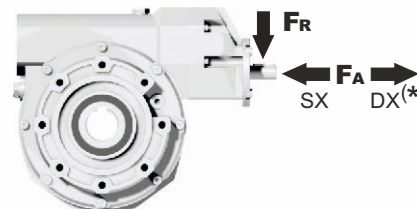

$n_1$ [min <sup>-1</sup> ]	FA [N]	FR [N]
1400	150	760

**\*Strong axial loads in the DX direction are not allowed.**  
Non sono consentiti forti carichi assiali con direzione DX

tab. 2

**PP10FB...** Basic wormbox  
Riduttore base

Gearbox weight  
peso riduttore **41.00 kg**

M. flanges	Kit code	øF	A
<b>63B5</b>	K063.4.041	140	214.7
<b>71B5</b>	K063.4.042	160	212.7
<b>80/90B5</b>	K063.4.043	200	214.7
<b>71B14</b>	K063.4.047	105	212.7
<b>80B14</b>	K063.4.046	120	214.7
<b>90B14</b>	K063.4.041	140	214.7

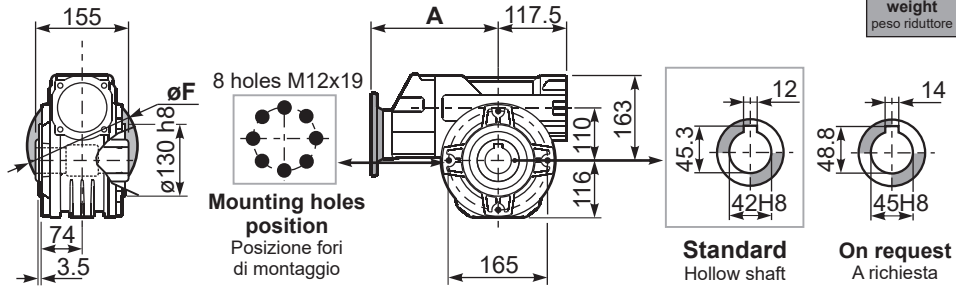

**PP10PA...** Feet  
Piedini

**PP10PB...** Feet  
Piedini

**PP10PV...** Feet  
Piedini

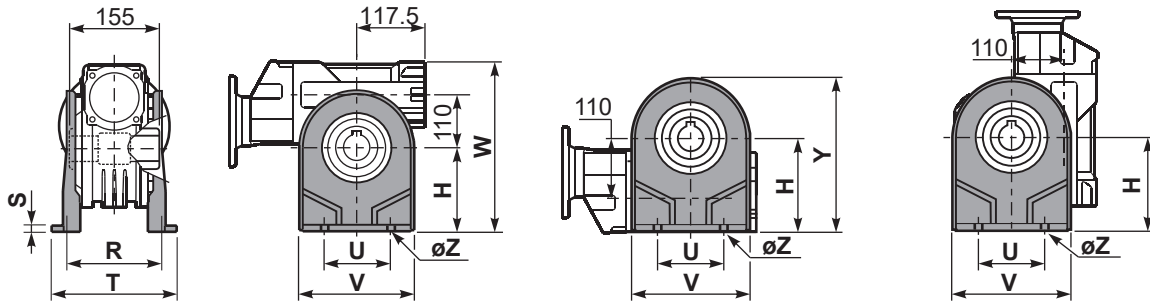

	H	R	S	T	U	V	Y	W	øZ	kit code
type B	170	180	22	224	200	240	286	333	ø13	K110.9.022
type S	-	-	-	-	-	-	-	-	-	-

**PP10FC...** Output flange  
Flangia uscita

**PP10BR...** Reaction arm  
Braccio di reazione

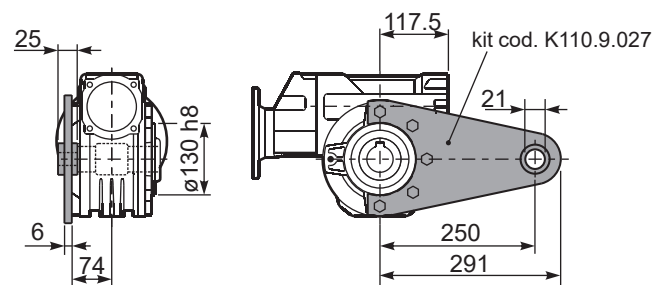
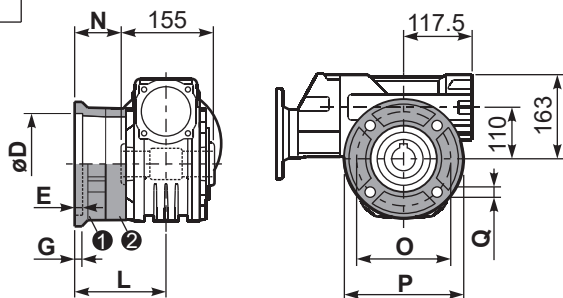

type B	øD	E	G	L	N	O	P	Q	kit code
<b>FC</b>	170 <sup>+0.083</sup> / <sub>+0.043</sub>	11	16.5	131.5	54	230	270	13	① K110.9.010 ② -
<b>FL</b>	170 <sup>+0.083</sup> / <sub>+0.043</sub>	11	16.5	179.5	102	230	270	13	① K110.9.011 ② -
type S	øD	E	G	L	N	O	P	Q	kit code
<b>F1</b>	180 <sup>+0.040</sup> / <sub>0</sub>	5	18	150	72.5	215	250	15	① KS110.9.014 ② -
<b>F3</b>	180 <sup>+0.040</sup> / <sub>0</sub>	5	18	130	52.5	215	250	15	① KS110.9.013 ② -

**PP10....S...** Single Shaft  
Albero lento semplice

**PP10....D...** Double Shaft  
Albero lento bisp.

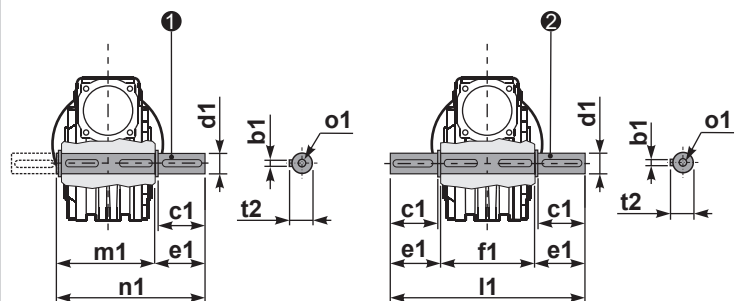

① kit cod. K110.5.028 type B

② kit cod. K110.5.029 type B

**RP10FB...** Input shaft  
Albero in entrata

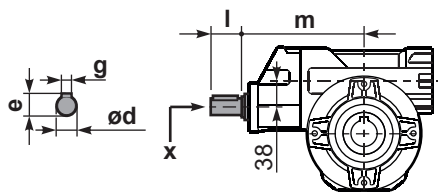

	ød	e	g	l	m	x
type B	19 h6	21.5	6	35	205	M6x16
type S	-	-	-	-	-	-

	b1	c1	d1	e1	f1	l1	m1	n1	t2	o1
type B	12	75	42 <sup>-0.005</sup> / <sub>-0.020</sub>	96.5	155	348	163.5	260	45	M12x32
type S	-	-	-	-	-	-	-	-	-	-