



QUICK SELECTION / Selezione veloce

input speed (n_1) = 1400 min⁻¹

Output Speed n_2 [min ⁻¹]	Ratio i	Motor power P_{1M} [kW]	Output torque M_{2M} [Nm]	Service factor f.s.	Nominal power P_{1R} [kW]	Nominal torque M_{2R} [Nm]	Available B5 motor flanges					Available B14 motor flanges				Output Shaft 	Ratios code	
							-C	-D	-E	-F	-G	-R	-T	-U	-V			
							71	80	90	100*	112	132*	80	90	100			112
388	3.61	5.5	127	1.2	6.6	155	B										3018	01
331	4.23	5.5	148	1.2	6.5	180	B										3016	02
279	5.01	5.5	176	1.2	6.4	210	B										3014	03
231	6.07	5.5	213	1.2	6.4	255	B										3012	04
206	6.81	5.5	239	1.3	6.7	300	B										2018	05
176	7.96	5.5	279	1.2	6.4	335	B										2016	07
148	9.45	5.5	331	1.1	5.8	360	B										2014	08
122	11.43	4	293	1.1	4.4	330	B										2012	09
100	14.00	3	270	1.3	3.9	360	B										1316	21
84	16.62	3	321	1.1	3.3	360	B										1314	11
70	20.10	2.2	286	1.2	2.5	330	B										1312	12
57	24.61	2.2	350	0.9	2.0	330	B										1112	20
47.6	29.41	1.5	288	1.2	1.9	360	B										814	14
39.3	35.58	1.5	349	0.9	1.4	330	B										812	15
34.6	40.50	1.1	290	1.1	1.2	320	B										614	16
31.7	44.23	1.1	316	0.8	0.88	255	B										810	17
28.6	49.00	1.1	351	0.9	1.0	330	B										612	18
23.0	60.90	0.75	299	0.8	0.64	255	B										610	19

The dynamic efficiency is **0.96** for all ratios

*Nel montaggio P la flangia può superare l'ingombro massimo dei piedi. Eventualmente utilizzare la flangia B14
* In the P mounting the B5 motor flange can exceed the foot maximum dimensions. Possibly use the flange B14

Motor Flanges Available
Flange Motore Disponibili

B) Supplied with Reduction Bushing
Fornito con Bussola di Riduzione

B) Available on Request without reduction bushing
Disponibile a Richiesta senza Bussola di Riduzione

C) Motor Flange Holes Position
Posizione Fori Flangia Motore

EN Unit **512A** is supplied with synthetic oil for lifetime lubrication, no maintenance is necessary. See table 1 for lubrication and recommended quantity. In table 2 please see possible radial loads and axial loads on the gearbox.

I Il riduttore **512A** viene fornito completo di olio sintetico per la lubrificazione permanente e non necessita di alcuna manutenzione. Vedi tab.1 per oli e quantità consigliati. In tab.2 sono presenti i carichi radiali e assiali applicabili al riduttore.

D Das Getriebe **512A** ist mit synthetischem Öl gefüllt und ist lebensdauergeschmiert. In Tabelle 1 ist die Schmiermenge und das empfohlene Schmiermittel angegeben. In Tabelle 2 sind die zulässigen Radial - und Axialbelastungen des Getriebes aufgeführt.

F Le réducteur **512A** est fourni complet avec de l'huile synthétique pour la lubrification permanente et ne nécessite aucun entretien. Voir tableau 1 concernant les huiles et les quantités conseillées. Les charges radiales et axiales applicables au réducteur sont précisées dans le tableau 2.

E El reductor tamaño **512A** se suministra, lubricado de por vida con aceite sintético y no requieren mantenimiento alguna. Ver tabla 1, para cantidades y aceites recomendados. En la tabla 2, se encuentran las cargas radiales y axiales admitidas por el reductor.

Standard supplied	For these mounting position specify in the order or add oil Per queste posizioni specificare in fase d'ordine o aggiungere olio					
B3	B6	B7	B8	V5	V6	V8
0.70 LT	0.80 LT	1.15 LT	1.20 LT	1.15 LT	1.25 LT	Ask
SHELL Omala S4 WE 320			ENI Telium VSF 320			

For all details on lubrication and plugs check our website **tab. 1**
Per maggiori dettagli su lubrificazione e tappi olio vedi il nostro sito web

RADIAL AND AXIAL LOADS

Output shaft
Albero di uscita

$F_{eq} = F_R \cdot \frac{54}{X+24}$

n_2	FA	FR	n_2	FA	FR	n_2	FA	FR
300	460	2300	140	600	3000	70	780	3900
250	480	2400	120	620	3100	40	900	4500
200	520	2600	85	700	3500	15	1000	5000

Input shaft
Albero in entrata

n_1	FA	FR
1400	450	2250
900	500	2500
500	600	3000

tab. 2

P512A **B1** ... With feet
Con piedini

Gearbox weight **11.7 kg**
peso riduttore With feet **11.9 Kg**

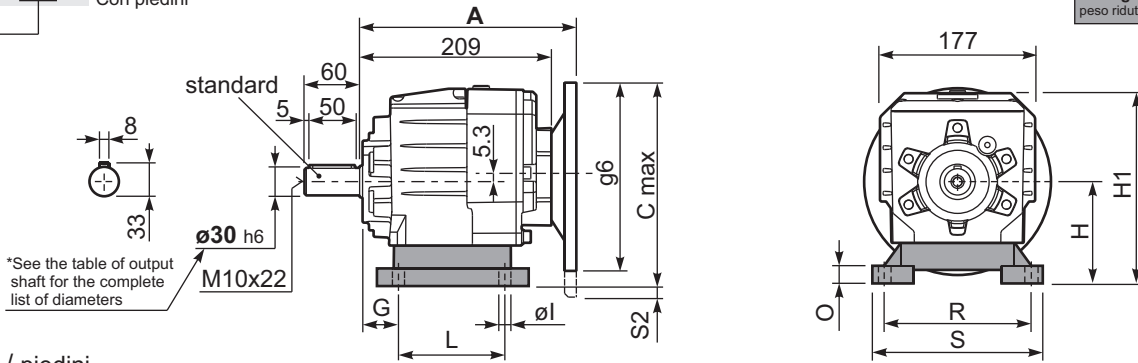

Feet / piedini

Feet Code	Market reference	G	H	R	L	S	H1	O	øl	S2 only with motor flange	B5 max. Flange	kit code
B3	312/3	18	110	160	130	190	211	20	11	10 100/112B5 35 132B5	-	KC50.9.024
B4	30/35	20	130	180	149.5	216	231	18	14	15 132B5	-	KC60.9.024
S4	47-57	30	115	135	165	170	216	25	14	5 100/112B5 30 132B5	-	KC50.9.022
H3	023-233	30	130	135	135	185	231	25	14	15 132B5	-	KC50.9.025
M2	52/3	30	110	135-150	100	190	211	18	11	10 100/112B5 35 132B5	-	KC50.9.023

Other feet are available, see our web site
Sono disponibili altri piedini, consulta il nostro sito web

A see on page bottom

Most popular types
Tipi più diffusi

P512A-**F** ... Output flanges
flange di uscita

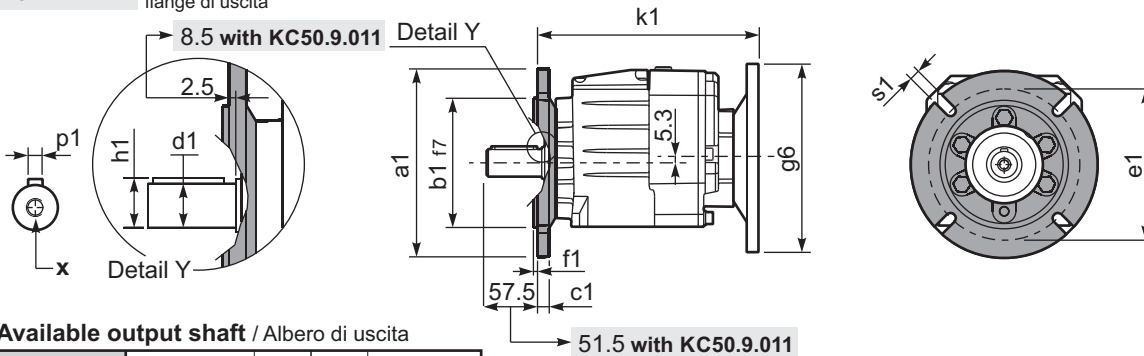

*Available output shaft / Alberi di uscita

	Shaft - d1	p1	h1	x
Standard	ø 30x60	8	33	M10x22
On request A richiesta	ø 24x50	8	27	M8x19
	ø 25x50	8	28	M8x19
	ø 28x60	8	31	M8x19
	ø 35x60	10	38	M10x22

Available output flanges / flange di uscita

a1 ø	b1	c1	e1	f1	s1	kit code
160	110	14	130	3.5	11	KC50.9.011
200	130	13	165	3.5	11	KC50.9.012
250	180	15.5	215	4	14	KC50.9.013

With flange and feet only on request.
Ask for compatibility

P512A-**N** ... Basic gearbox
Riduttore base

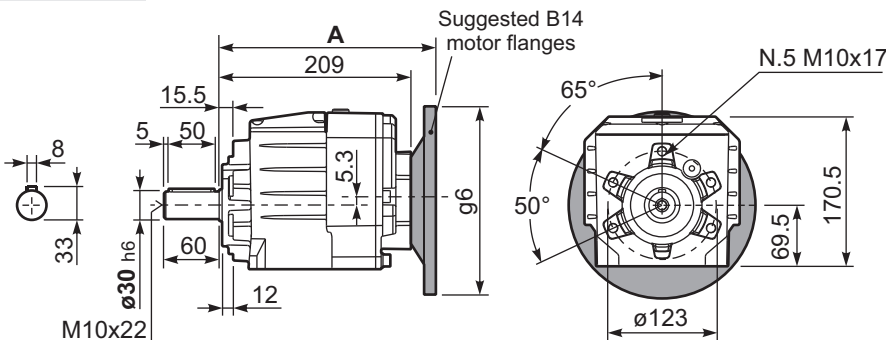

R512A-N ... Input Shaft
Albero in entrata

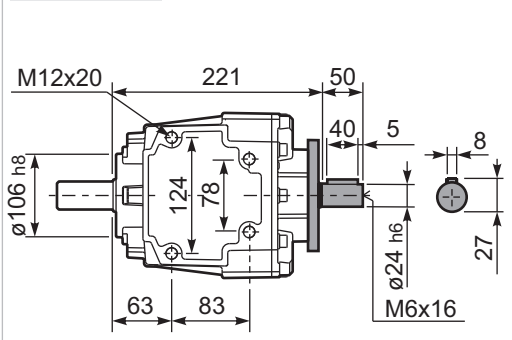

B5 Motor Flanges	A	C _{max}	g6	k1	kit code	k1 with KC50.9.011	B14 Motor Flanges	A	C _{max}	g6	k1	kit code	k1 with KC50.9.011
71 B5	227.5	227.3	160	230	K023.4.041	236	80 B14	229.5	207.3	120	232	K085.4.046	238
80/90 B5	229.5	247.3	200	232	K023.4.042	238	90 B14	229.5	217.3	140	232	K085.4.045	238
100/112 B5	238.5	272.3	250	241	K023.4.043	247	100/112 B14	238.5	227.3	160	241	K085.4.047	247
132 B5	259.5	297.3	300	259	KC51.4.043	265	132 B14	259.5	247	200	259	KC51.4.041	265