



**QUICK SELECTION / Selezione veloce**

input speed ( $n_1$ ) = 1400 min<sup>-1</sup>

Output Speed $n_2$ [min <sup>-1</sup> ]	Ratio $i$	Motor power $P_{1M}$ [kW]	Output torque $M_{2M}$ [Nm]	Service factor f.s.	Nominal power $P_{1R}$ [kW]	Nominal torque $M_{2R}$ [Nm]	Available B5 motor flanges				Available B14 motor flanges			Output Shaft 	Ratios code	
							-B	-C	-D	-E	-Q	-R	-T			
							63	71	80	90	71	80	90			
891	<b>1.57</b>	1.5	16	1.3	<b>1.9</b>	<b>20</b>	B				C	C		2844	standard ø19  On request ø14 ø24	01
493	<b>2.84</b>	1.5	28	1.2	<b>1.8</b>	<b>35</b>	B				C	C		1954		02
425	<b>3.29</b>	1.5	33	1.2	<b>1.7</b>	<b>38</b>	B				C	C		1756		03
362	<b>3.87</b>	1.5	39	1.0	<b>1.5</b>	<b>40</b>	B				C	C		1558		04
303	<b>4.62</b>	1.5	46	1.0	<b>1.5</b>	<b>47</b>	B				C	C		1360		05
222	<b>6.30</b>	1.1	46	1.0	<b>1.1</b>	<b>46</b>	B				C	C		1063		06
170	<b>8.22</b>	0.55	30	1.3	<b>0.69</b>	<b>38</b>	B				C	C		974		07
129	<b>10.86</b>	0.37	27	1.0	<b>0.39</b>	<b>28</b>	B				C	C		776		08

The dynamic efficiency is **0.98** for all ratios

**Motor Flanges Available**  
Flange Motore Disponibili

**B) Supplied with Reduction Bushing**  
Fornito con Bussola di Riduzione

**B) Available on Request without reduction bushing**  
Disponibile a Richiesta senza Bussola di Riduzione

**C) Motor Flange Holes Position**  
Posizione Fori Flangia Motore

**EN** Unit **411A** is supplied with synthetic oil for lifetime lubrication, no maintenance is necessary. See table 1 for lubrication and recommended quantity. In table 2 please see possible radial loads and axial loads on the gearbox.

**I** Il riduttore **411A** viene fornito completo di olio sintetico per la lubrificazione permanente e non necessita di alcuna manutenzione. Vedi tab.1 per oli e quantità consigliati. In tab.2 sono presenti i carichi radiali e assiali applicabili al riduttore.

**D** Das Getriebe **411A** ist mit synthetischem Öl gefüllt und ist lebensdauer geschmiert. In Tabelle 1 ist die Schmiermenge und das empfohlene Schmiermittel angegeben. In Tabelle 2 sind die zulässigen Radial - und Axialbelastungen des Getriebes aufgeführt.

**F** Le réducteur **411A** est fourni complet avec de l'huile synthétique pour la lubrification permanente et ne nécessite aucun entretien. Voir tableau 1 concernant les huiles et les quantités conseillées. Les charges radiales et axiales applicables au réducteur sont précisées dans le tableau 2.

**E** El reductor tamaño **411A** se suministra, lubricado de por vida con aceite sintético y no requieren mantenimiento alguna. Ver tabla 1, para cantidades y aceites recomendados. En la tabla 2, se encuentran las cargas radiales y axiales admitidas por el reductor.

**LUBRICATION 411A Oil Quantity 0.10 Lt.**

**AGIP** Telium VSF 320

**SHELL** Omala S4 WE 320

For all details on lubrication and plugs check our website

tab. 1

Per maggiori dettagli su lubrificazione e tappi olio vedi il nostro sito web

**RADIAL AND AXIAL LOADS**

**Output shaft**

Albero di uscita

$$F_{eq} = F_R \cdot \frac{40}{X+20}$$

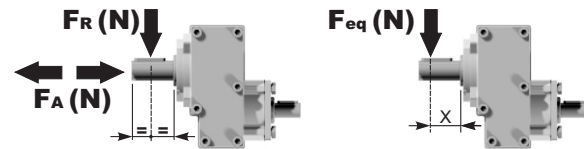

$n_2$	FA	FR	$n_2$	FA	FR	$n_2$	FA	FR
700	182	910	400	230	1150	200	290	1450
600	200	1000	300	250	1250	140	320	1600

**Input shaft**

Albero in entrata

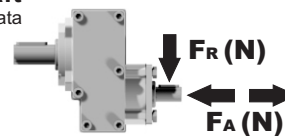

$n_1$	FA	FR
1400	240	1200
900	280	1400

tab. 2

**P411-F...** Output flange  
flange di uscita

Gearbox weight  
peso riduttore **3.20 kg**

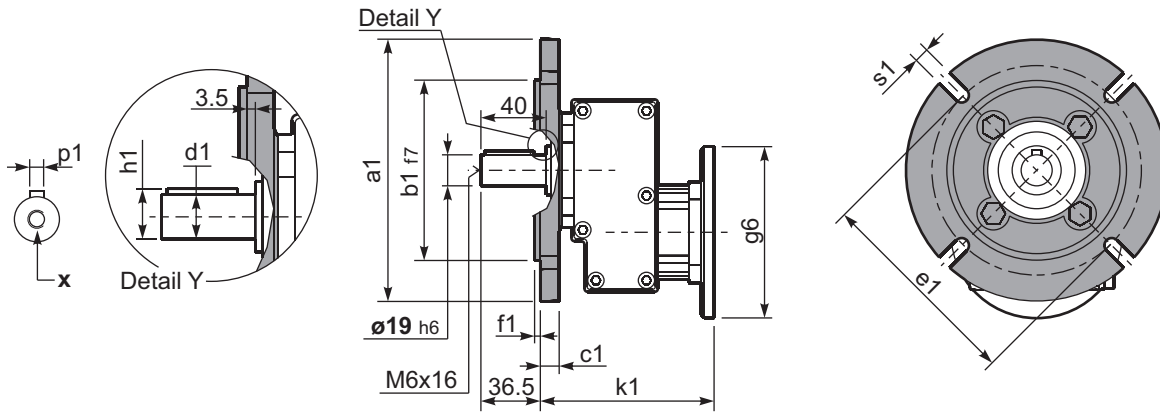

**\*Available output shaft / Albero di uscita**

	Shaft - d1	p1	h1	x
Standard	∅ 19x40	6	21.5	M6x16
On request A richiesta	∅ 14x30 ∅ 24x40	5 8	16 27	M5x13 M6x16

**Available output flanges / flange di uscita**

a1 ∅	b1	c1	e1	f1	s1	kit code
120	80	11.5	100	3	9*	KC30.9.010
140	95	11.5	115	3	9	KC30.9.011
160	110	11.5	130	3.5	9	KC30.9.012
200	130	11.5	165	3.5	11	KC30.9.013

\*Holes position  
posizione fori



**P411-H1...** With feet  
Con piedini

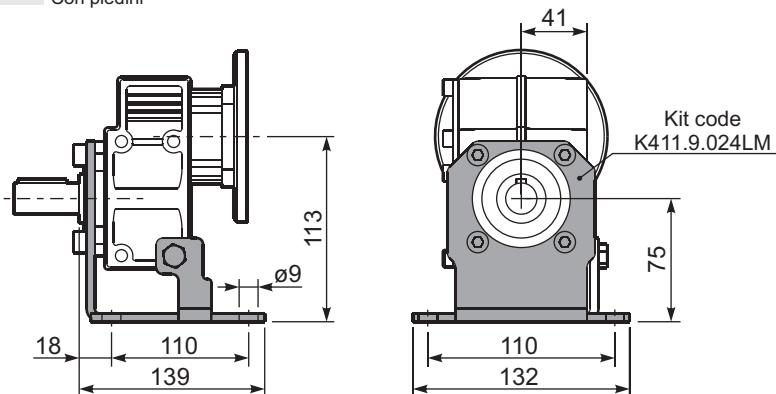

**R411-N...** Input Shaft  
Albero in entrata

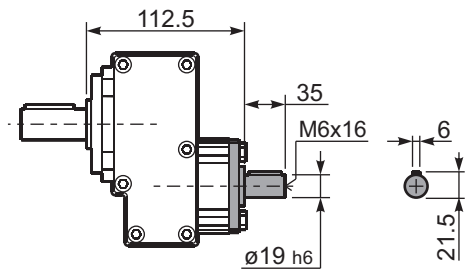

**P411-N...** Basic gearbox  
Riduttore base

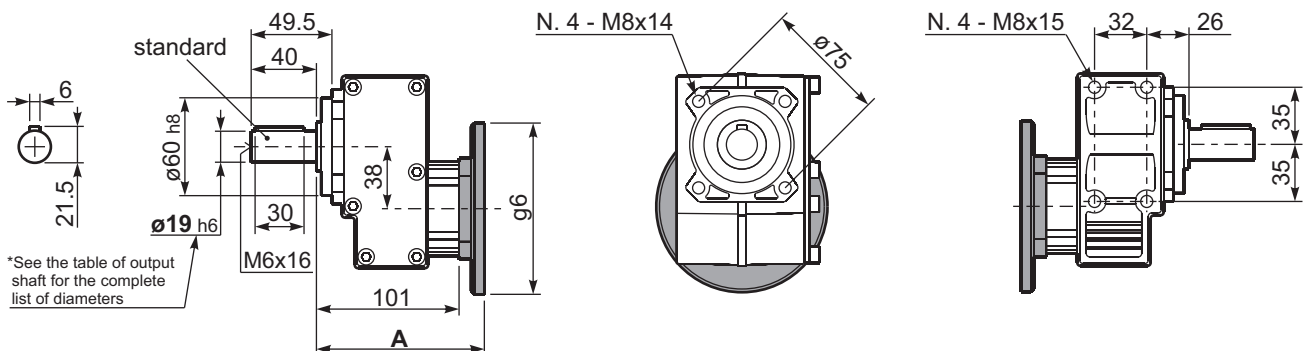

\*See the table of output shaft for the complete list of diameters

B5 Motor Flanges	A	g6	k1	kit code
63 B5	121.5	140	125	K063.4.041
71 B5	119.5	160	123	K063.4.042
80/90 B5	121.5	200	125	K063.4.043

B14 Motor Flanges	A	g6	k1	kit code
71 B14	119.5	105	123	K063.4.047
80 B14	121.5	120	125	K063.4.046
90 B14	121.5	140	125	K063.4.041