



QUICK SELECTION / Selezione veloce The dynamic efficiency is **0.96** for all ratios **input speed (n₁) = 1400 min⁻¹**

Output Speed n ₂ [min ⁻¹]	Ratio i	Motor power P _{1M} [kW]	Output torque M _{2M} [Nm]	Service factor f.s.	Nominal power P _{1R} [kW]	Nominal torque M _{2R} [Nm]	Available B5 motor flanges		Available B14 motor flanges			Output Shaft 	Ratios code
							-B	-C	-O	-P	-Q		
							63	71*	56	63	71		
407	3.44	0.55**	12	2.0	1.1	25			C	C		2821	01
327	4.28	0.55**	15	1.9	1.1	30			C	C		2818	02
257	5.45	0.55**	20	2.0	1.1	40			C	C		2815	03
225	6.23	0.55**	23	2.0	1.1	45			C	C		1921	04
194	7.20	0.55**	26	1.9	1.1	50			C	C		2812	05
181	7.74	0.55**	28	1.8	0.99	50			C	C		1918	06
142	9.85	0.55**	36	1.7	0.93	60			C	C		1915	07
123	11.42	0.55**	41	1.5	0.80	60			C	C		1715	08
107	13.03	0.55**	47	1.3	0.70	60			C	C		1912	09
93	15.10	0.37	37	1.6	0.61	60			C	C		1712	10
86	16.20	0.37	39	1.5	0.57	60			C	C		1910	11
75	18.78	0.37	45	1.3	0.49	60			C	C		1710	12
66	21.15	0.37	51	1.2	0.43	60			C	C		1312	13
64	21.84	0.37	53	1.1	0.42	60			C	C		1015	14
53	26.31	0.37	64	0.9	0.35	60			C	C		1310	15
48.5	28.88	0.37	70	1.0	0.37	70			C	C		1012	16
39	35.91	0.37	87	0.8	0.30	70			C	C		1010	17
37.1	37.69	0.25	62	1.1	0.28	70			C	C		912	18
29.9	46.87	0.25	77	0.9	0.23	70			C	C		910	19
28.1	49.76	0.25	81	0.9	0.21	70			C	C		712	20
22.6	61.89	0.18	77	0.9	0.17	70			C	C		710	21

** Concerning a reduced dimensions electric motor. * Nel montaggio P la flangia può superare l'ingombro massimo dei piedi. Eventualmente utilizzare la flangia B14 Riferito a motore con grandezza ridotta * In the P mounting the B5 motor flange can exceed the foot maximum dimensions. Possibly use the flange B14

A) Motor Flanges Available Flange Motore Disponibili **B) Supplied with Reduction Bushing** Fornito con Bussola di Riduzione **C) Available on Request without reduction bushing** Disponibile a Richiesta senza Bussola di Riduzione **D) Motor Flange Holes Position** Posizione Fori Flangia Motore

EN Unit **202A** is supplied with synthetic oil for lifetime lubrication, no maintenance is necessary. See table 1 for lubrication and recommended quantity. In table 2 please see possible radial loads and axial loads on the gearbox.

I Il riduttore **202A** viene fornito completo di olio sintetico per la lubrificazione permanente e non necessita di alcuna manutenzione. Vedi tab.1 per oli e quantità consigliati. In tab.2 sono presenti i carichi radiali e assiali applicabili al riduttore.

D Das Getriebe **202A** ist mit synthetischem Öl gefüllt und ist lebensdauergeschmiert. In Tabelle 1 ist die Schmiermenge und das empfohlene Schmiermittel angegeben. In Tabelle 2 sind die zulässigen Radial - und Axialbelastungen des Getriebes aufgeführt.

F Le réducteur **202A** est fourni complet avec de l'huile synthétique pour la lubrification permanente et ne nécessite aucun entretien. Voir tableau 1 concernant les huiles et les quantités conseillées. Les charges radiales et axiales applicables au réducteur sont précisées dans le tableau 2.

E El reductor tamaño **202A** se suministra, lubricado de por vida con aceite sintético y no requieren mantenimiento alguna. Ver tabla 1, para cantidades y aceites recomendados. En la tabla 2, se encuentran las cargas radiales y axiales admitidas por el reductor.

LUBRICATION 202A Oil Quantity 0.15 Lt.

AGIP Telium VSF 320 **SHELL** Omala S4 WE 320

For all details on lubrication and plugs check our website **tab. 1**
Per maggiori dettagli su lubrificazione e tappi olio vedi il nostro sito web

RADIAL AND AXIAL LOADS

Output shaft
Albero di uscita

$F_{eq} = F_R \cdot \frac{35.7}{X+20.7}$

Input shaft
Albero in entrata

n ₂	FA	FR	n ₂	FA	FR	n ₂	FA	FR
300	140	700	140	246	1320	70	340	1700
250	151	756	120	270	1350	40	380	1900
200	185	924	85	300	1500	15	-	-

n ₁	FA	FR
1400	140	700
900	160	800
500	190	950

tab. 2

Gearbox weight **3.3 kg**
 With flange
 peso riduttore **3.7 Kg**
 With feet

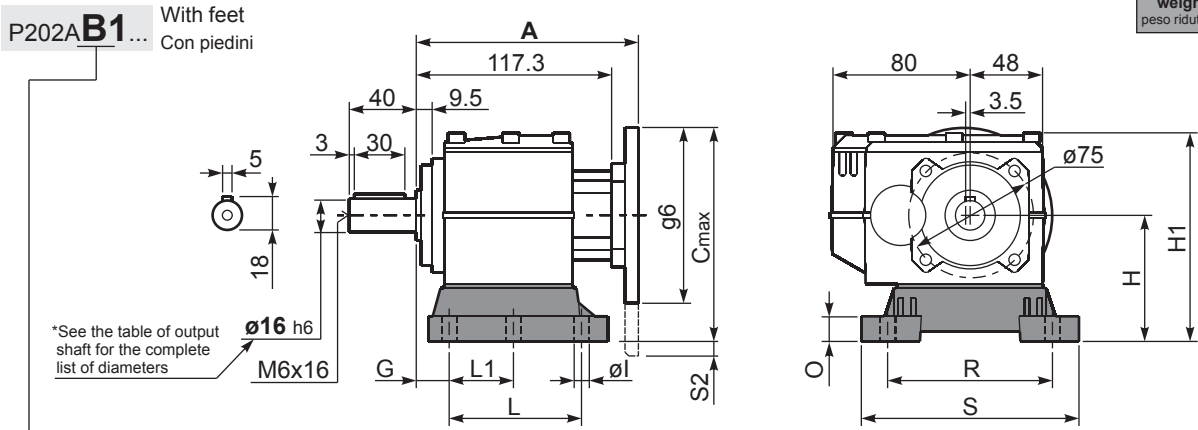

Feet Code	Market reference	G	H	R	L	L1	S	H1	O	Ø1	S2 only with motor flange	B5 max. Flange	kit code
B1	112	18	85	110	87	50	130	133	15	9	-	-	KC30.9.022
B2	212/3	18	100	130	107.5	60	155	145	5	11	-	-	KC30.9.023LM
S1	17-32	18	75	110	110	50	130	123	15	9	-	63B5	KC30.9.024

Other feet are available, see our web site
 Sono disponibili altri piedini, consulta il nostro sito web

A see on page bottom

Most popular types
 Tipi più diffusi

P202A-F... Output flanges
 flange di uscita

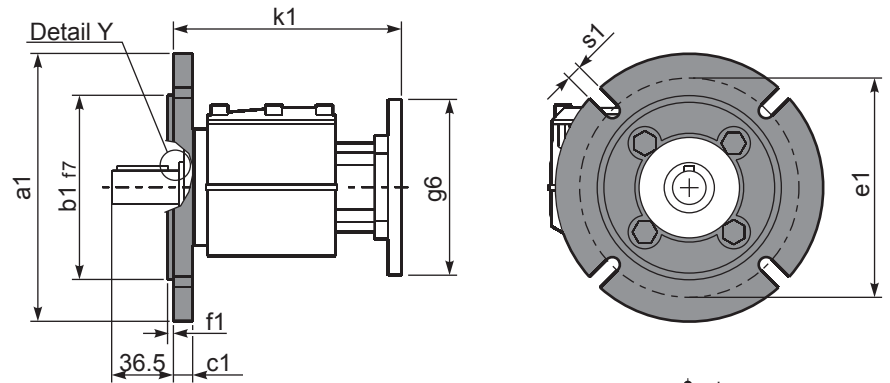
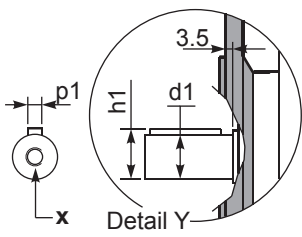

*Available output shaft / Albero di uscita

	Shaft - d1	p1	h1	x
Standard	Ø 16x40	5	18	M6x16
On request A richiesta	Ø 14x30	5	16	M6x16
	Ø 20x40	6	22.5	M8x19
	Ø 25x50	8	28	M8x19

Available output flanges / flange di uscita

a1 Ø	b1	c1	e1	f1	s1	kit code
120	80	11.5	100	3	9*	KC30.9.010
140	95	11.5	115	3	9	KC30.9.011
160	110	11.5	130	3.5	9	KC30.9.012
200	130	11.5	165	3.5	11	KC30.9.013

* Holes position
 Posizione fori

With flange and feet only on request. Ask for compatibility

P202A-N... Basic gearbox
 Riduttore base

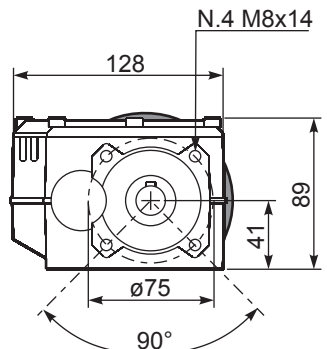
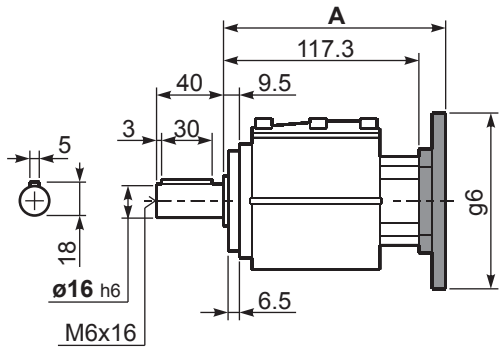

R202A-N... Input Shaft
 Albero in entrata

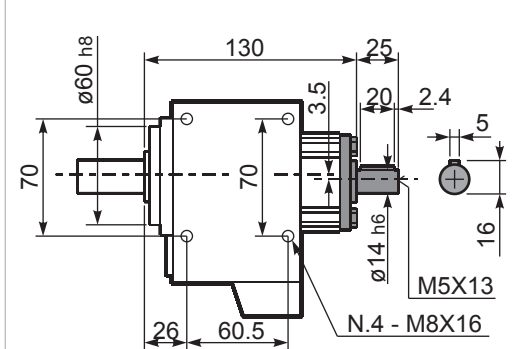

B5 Motor Flanges	A	C _{max}	g6	k1	kit code
63 B5	135.8	170	140	139.3	K050.4.041
71 B5	133.3	180	160	136.8	K050.4.042

B14 Motor Flanges	A	C _{max}	g6	k1	kit code
56 B14	133.3	139	80	136.8	KC40.4.049
63 B14	135.8	146	90	139.3	K050.4.047
71 B14	133.3	152.5	105	136.8	K050.4.045