



#### QUICK SELECTION / Selezione veloce

input speed ( $n_1$ ) = 1400 min<sup>-1</sup>

Output Speed $n_2$ [min <sup>-1</sup> ]	Ratio $i$	Motor power $P_{1M}$ [kW]	Output torque $M_{2M}$ [Nm]	Service factor f.s.	Nominal power $P_{1R}$ [kW]	Nominal torque $M_{2R}$ [Nm]	Available B5 motor flanges					Available B14 motor flanges				Dynamic efficiency RD	Tooth Module [mm]	Ratios code	
							-C	-D	-E	-F	-G	-R	-T	-U	-V				
							71	80	90	100 112	132	80	90	100 112	132				
200	7	7.5	315	1.5	11.5	483		B	B				B	B			88	5.5	01
140	10	7.5	440	1.2	9.0	525		B	B				B	B			86	5.4	02
88	16	5.5	492	1.1	6.0	536		B	B				B	B			82	5.3	03
70	20	4.0	447	1.2	4.9	546		B	B				B	B			82	4.5	04
61	23	3.0	377	1.4	4.1	515		B	B				B	B			80	3.9	05
47	30	3.0	467	1.4	4.2	651		B	B				B	B			76	5.6	06
37	38	3.0	583	1.1	3.3	641		B	B				B	B			75	4.7	07
31	45	2.2	493	1.2	2.7	599		B	B				B	B			73	4.0	08
26	53	2.2	557	1.1	2.5	620		B	B				B	B			70	3.5	09
22	64	1.5	452	1.2	1.8	536	B	B					B				69	2.9	10
16.7	84	1.1	410	1.2	1.3	494	B	B					B				65	2.2	11
14.1	99	1.1	446	1.1	1.2	483	B	B					B				60	1.9	12

  Motor Flanges Available Flange Motore Disponibili  
B Supplied with Reduction Bushing Fornito con Bussola di Riduzione  
B Available on Request without reduction bushing Disponibile a Richiesta senza Bussola di Riduzione  
C Motor Flange Holes Position Posizione Fori Flangia Motore

**EN** Unit Q11 is supplied without lubricant and equipped with a breather, level and drain plugs. User can add mineral oil keeping existing plugs. Should the user wish to fill it with synthetic oil, it is recommended to replace the existing plugs with a closed plug. See table 1 for lubrication and recommended quantity. In table 2 please see possible radial loads and axial loads on the gearbox.

**I** Il riduttore tipo Q11 è fornito privo di lubrificazione con tappi di sfiato, livello e scarico olio. L'utente può immettere olio minerale mantenendo i tappi esistenti. Se immetterà olio sintetico, dovrà sostituire i tappi esistenti con altri tipo chiuso. Tab.1 per oli e quantità consigliati. Tab.2 carichi radiali e assiali applicabili al riduttore.

**D** Das Getriebe der Baugröße Q11 wird ohne Schmiermittel geliefert. Es ist jedoch mit Einfüllschraube, Überdruckventil und Ablassschraube ausgerüstet. Das benötigte mineralische Öl kann über die Einfüllschraube eingefüllt werden. Sollte synthetisches Öl bevorzugt werden, so ist sind das eingebaute Überdruckventil durch eine geschlossenen Schraube zu ersetzen. In Tabelle 1 ist die Schmiermenge und das empfohlene Schmiermittel angegeben. In Tabelle 2 sind die zulässigen Radial - und Axialbelastungen des Getriebes aufgeführt.

**F** Le réducteur de type Q11 est fourni sans lubrification et avec un bouchon de remplissage, de niveau et d'évacuation de l'huile. L'utilisateur peut y verser de l'huile minérale en conservant les bouchons existants. S'il y versera de l'huile synthétique, il devra substituer les bouchons existants avec d'autres bouchons de type fermé. Voir tableau 1 concernant les huiles et les quantités conseillées. Voir tableau 2 concernant les charges radiales et axiales applicables au réducteur.

**E** El reductor tamaño Q11 se suministra sin lubricante, provisto de tapones de respiración, nivel y descarga de aceite. El usuario puede utilizar aceite mineral, manteniendo los tapones existentes. Si prefiere utilizar aceite sintético deberá sustituir los tapones existentes por tapones ciegos. La prerreducción se suministra con tapones ciegos, lubricado de por vida con aceite sintético. Ver tabla 1, para cantidades y aceites recomendados. En la tabla 2, se encuentran las cargas radiales y axiales admitidas por el reductor.

B3	B6	B7	B8	V5	V6
1.90 LT	1.35 LT	1.35 LT	2.00LT	2.00 LT	2.00LT
AGIP Blasias 460					

For all details on lubrication and plugs check our website [tab. 1](#)  
Per maggiori dettagli su lubrificazione e tappi olio vedi il nostro sito web

#### RADIAL AND AXIAL LOADS

##### Output shaft Albero di uscita

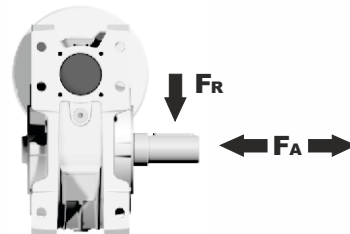

$n_2$ [min <sup>-1</sup> ]	FA [N]	FR [N]
200	600	2900
150	700	3300
100	750	3600
75	800	4000
50	920	4600
25	1200	6000
15	1400	7000

##### Input shaft albero in entrata

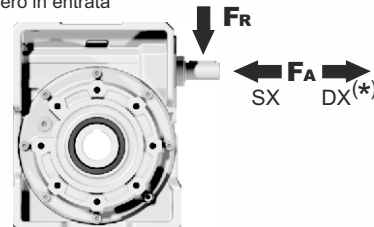

$n_1$ [min <sup>-1</sup> ]	FA [N]	FR [N]
1400	228	1140

\*Strong axial loads in the DX direction are not allowed.  
Non sono consentiti forti carichi assiali con direzione DX

tab. 2

**PQ11FB...** Basic wormbox  
Riduttore base

Gearbox weight  
peso riduttore **35.0 kg**

M. flanges	Kit code	øF	A
71B5	K023.4.041	160	136
80/90B5	K023.4.042	200	138
100/112B5	K023.4.043	250	147
132B5	-	300	187
80B14	K085.4.046	120	138
90B14	K085.4.045	140	138
100/112B14	K023.4.041	160	136
132B14	-	200	187

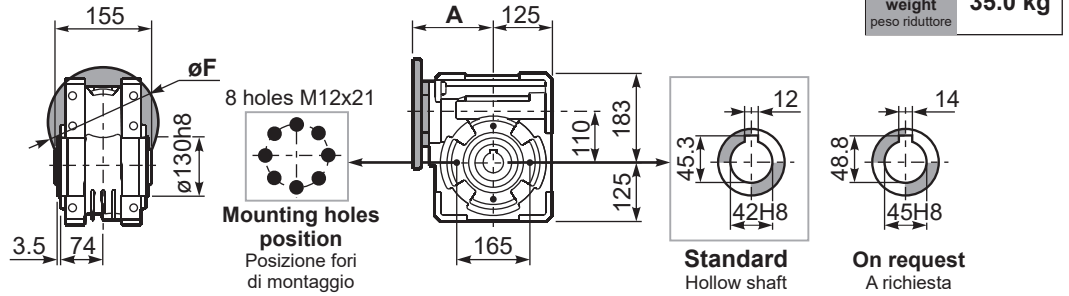

**PQ11FC...** Output flange  
Flangia uscita

**PQ11F1...** Output flange  
Flangia uscita

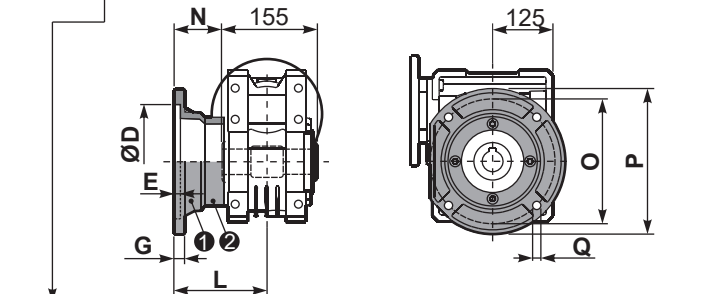
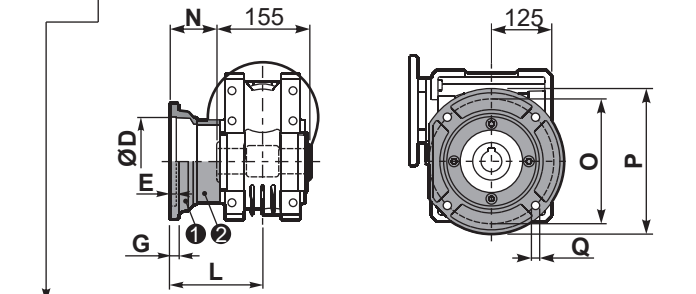

type B	øD	E	G	L	N	O	P	Q	kit code
FC	170 <sup>+0.083</sup> / <sub>+0.043</sub>	11	16.5	131.5	54	230	270	13	① K110.9.010 ② -
FL	170 <sup>+0.083</sup> / <sub>+0.043</sub>	11	16.5	179.5	102	230	270	13	① K110.9.011 ② -

type S	øD	E	G	L	N	O	P	Q	kit code
F1	180 <sup>+0.040</sup> / <sub>0</sub>	5	18	150	72.5	215	250	15	① KS110.9.014 ② -
F3	180 <sup>+0.040</sup> / <sub>0</sub>	5	18	130	52.5	215	250	15	① KS110.9.013 ② -

**PQ11FB...** Feet  
Piedini

**PQ11BR...** Reaction arm  
Braccio di reazione

kit cod. K110.9.027

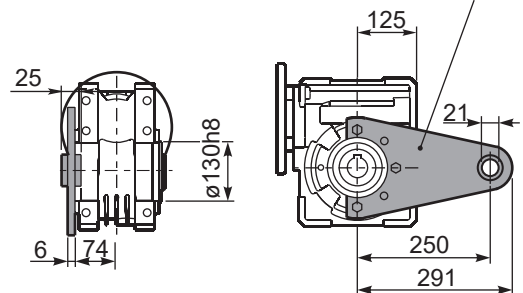
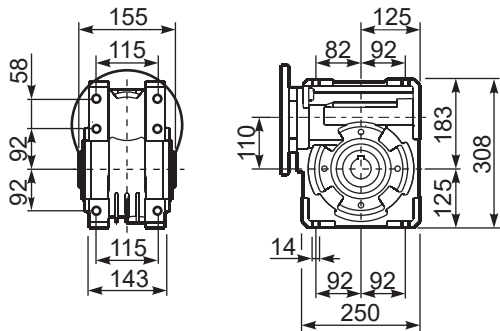

**RQ11FB...** Input shaft  
Albero in entrata

**PQ11.....S...** Single Shaft  
Albero lento semplice

**PQ11.....D...** Double Shaft  
Albero lento bisp.

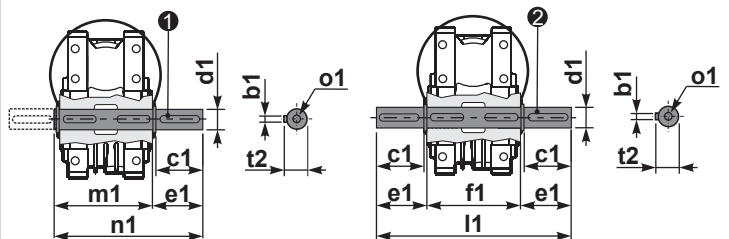
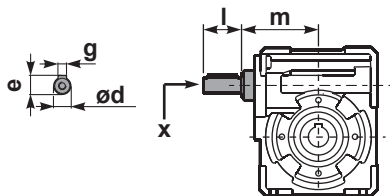

① kit cod. K110.5.028 type B    ② kit cod. K110.5.029 type B

	ød	e	g	l	m	x	kit code
type B	25 h6	28	8	50	131.5	M8x20	① K085.5.007 PAM90 ② K085.5.008 PAM100
type S	24 h6	27	8	50	131.5	M8x20	① KS085.5.009 PAM90 ② KS085.5.011 PAM100

	b1	c1	d1	e1	f1	l1	m1	n1	t2	o1
type B	12	75	42 <sup>-0.005</sup> / <sub>-0.020</sub>	96.5	155	348	163.5	260	45	M12x32
type S	-	-	-	-	-	-	-	-	-	-